

Elettropompe sommergibili con girante Vortex

Submersible electropumps with Vortex impeller

Potenze / Power:	12÷55 kW
Mandate / Delivery:	DN100 - 150



Impieghi

La serie VT 4 poli trova impiego nel pompaggio nella movimentazione di liquidi fognari particolarmente pesanti. Alte prestazioni e ampi passaggi rendono la serie adatta ad essere impiegata nell'industria, nella zootecnia, sul convogliamento di fanghi, concree, ed ovunque ci sia la necessità di pompare liquidi con pezzi solidi di grandi dimensioni.

Caratteristiche

Tutti i componenti principali sono realizzati in Ghisa GG25. Due tenute meccaniche separate (lato motore a bagno olio, lato girante a contatto con il liquido) e componentistica di prima qualità, ne garantiscono il perfetto funzionamento.

Motori

- Motori asincroni 4 poli con rotore a gabbia di scoiattolo
- Protezione termica T1 e T2 incorporato nel motore da collegare ad un apposito quadro di comando
- Isolamento statore classe F (155°C)
- Grado protezione IP 68

Raffreddamento

Raffreddamento effettuato dal liquido nel quale la pompa è immersa.

Limiti di impiego

- Temperatura massima del liquido: 40°C con unità completamente sommersa
- Disponibili versioni speciali (escluso ATEX) fino alla temperatura liquido di 60°C con unità completamente sommersa, non a servizio continuo (S1)
- Massima profondità di immersione: 20 mt
- Valori pH ammessi: 6-10
- Caratteristiche idrauliche valide per liquidi di densità <math><1,1 \text{ kg/dm}^3</math>
- Tensioni ammesse: 400/690V $\pm 5\%$
- Frequenza ammessa: 50Hz $\pm 2\%$

Application

The VT 4 poles Series is used for transport of water with heavy suspended solids. High performance and a wide channel permits its use in industry, including tanneries and farms, and for the movement of water contaminated with soil, or containing large solid pieces.

Characteristic

All main components are made of grey cast iron GG25. Two individual mechanical seals (motor side in the oil chamber, impeller side in contact with the liquid) and high quality parts, ensure the perfect functioning and reliability of the product.

Motor range

- Squirrel cage motor 4 poles
- Thermal protection T1 and T2 embedded in the motor winding (to be wired to the three pole contactor in the control panel)
- Class F insulation (155°C)
- IP 68 protection

Motor cooling

The cooling of the motor is ensured by the liquid where the pump is submerged.

Limits of use

- Max. permissible liquid temperature: 40°C with pump fully submerged
- On request, special version (excluded ATEX) to withstand liquid temperature up to 60°C with pump fully submerged, no S1 service
- Maximum depth of immersion: 20 mt.
- Permissible pH value: 6-10
- Hydraulic features suitable for liquids with density <math><1,1 \text{ kg/dm}^3</math>
- Allowed voltage: 400/690V $\pm 5\%$
- Allowed frequency: 50Hz $\pm 2\%$

Designazione / Designation

VT-EX 100 / 4 / 200 C.363

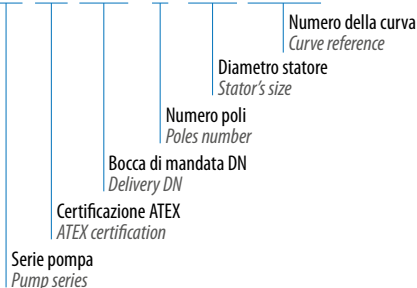

Campo di Prestazione / Performance Overview

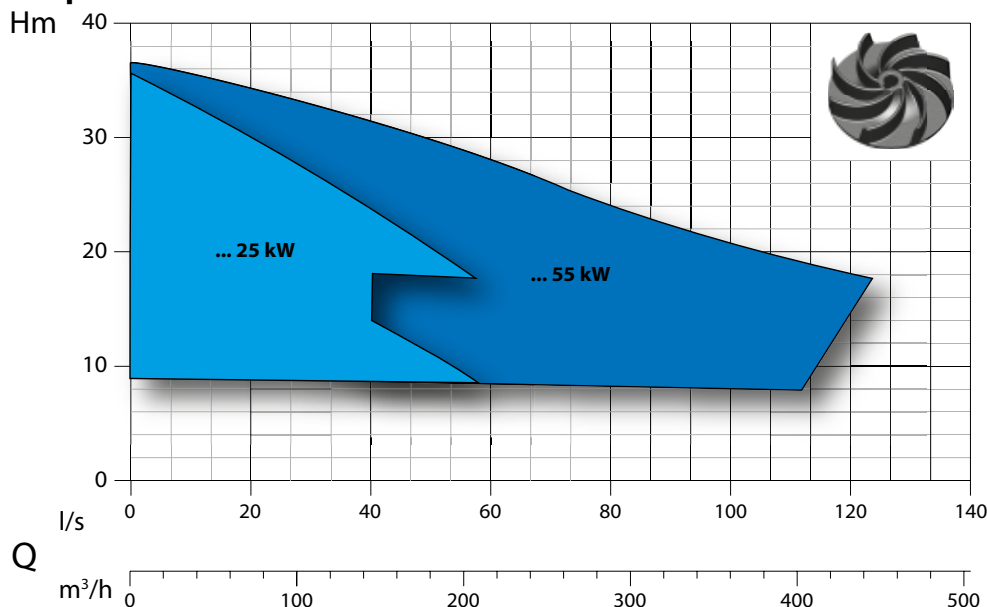

Identificazione Curve

Curves Identification

- DN100
- DN150

Normative

Norms

Curve secondo ISO 9906:2012 3B2
According to ISO 9906:2012 3B2

Distinta dei componenti e materiali List of components and materials

V4

Golfare - Hook

Acciaio inox AISI 416 - Stainless steel AISI 416

Porta cuscinetto superiore - Upper bearing support

Ghisa GG25 - Cast Iron GG25

Cassa motore - Motor casing

Ghisa GG25 - Cast iron GG25

Cuscinetto superiore - Upper bearing

Albero motore - Motor shaft

Acciaio inox AISI 420 - Stainless steel AISI 420

Motore elettrico - Electric motor

Rotore - Rotor

Cuscinetto inferiore - Lower bearing

Porta motore - Motor holder

Ghisa GG25 - Cast iron GG25

Tenuta meccanica - Mechanical seal

Carburo di silicio - Silicon/Carbide (SiC/SiC/Viton)

Disco di chiusura - Closing Plate

Ghisa GG25 - Cast iron GG25

Tenuta meccanica - Mechanical seal

Carburo di silicio - Silicon/Carbide (SiC/SiC/Viton)

Corpo pompa - Body pump

Ghisa GG25 - Cast iron GG25

Girante - Impeller

Ghisa GG25 - Cast iron GG25

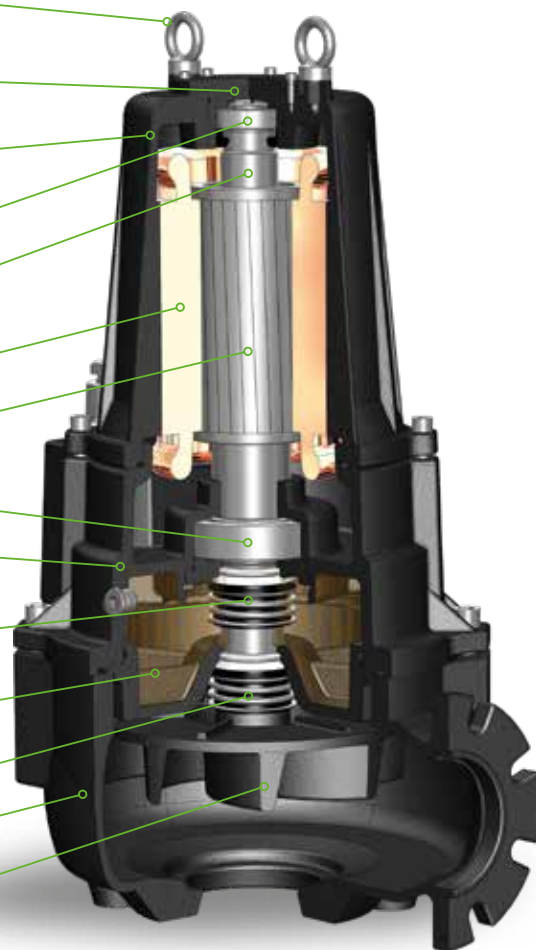

Tecnologie e Soluzioni Technology and Features

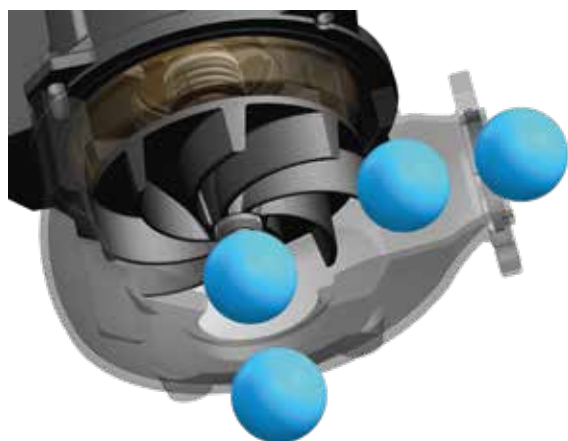

Giranti

I giranti sono stati sviluppati per offrire sempre ottime prestazioni, senza rinunciare ad ampi passaggi di corpi solidi.

Impellers

Impellers have been studied to grant excellent performances and ample solid handling.



Pompe antideflagranti / Explosion proof pumps

CE 0477



Ex db IIB T4 Gb
Ex h IIB T4 Gb
0° ≤ Ta ≤ 40°

EPT 17 ATEX 2703 X

I presenti certificati garantiscono la sicurezza contro le esplosioni, in assoluta conformità con le stringenti direttive europee ed internazionali ATEX/IECEx.

These certificates grant for the safe use of the product in hazardous area in line with the stringent European and International standards ATEX/IECEx.



Sensore d'umidità

Sensore conforme alle norme sulla sicurezza integrata contro le esplosioni EN 60079-0, EN 60079-1 tramite barriera di protezione. Di serie su tutta la gamma (non applicabile con IECEx).

Seal leak detector

The seal leak detector is certified according to the norm EN 60079-0, EN 60079-1 (through safety barrier). Standard on all series (not applicable with IECEx).

Cuscinetti

La serie monta il cuscinetto superiore a rulli cilindrici, atto ad assorbire e resistere ad eventuali sollecitazioni trasmesse dall'albero motore.



Bearings

The series is fitted with a cylindrical roller bearing (upper bearing) to absorb the thrust and vibration generated by the pump shaft.

Mandata Orizzontale DN100 PN16 - RPM 1450 1/min 4 poli

Horizontal Outlet DN100 PN16 - RPM 1450 1/min 4 poles

Immagine a solo scopo illustrativo
Picture for illustration purposes only



Curva di Prestazione Performance Curve

L = rendimento massimo pompa
maximum pump efficiency

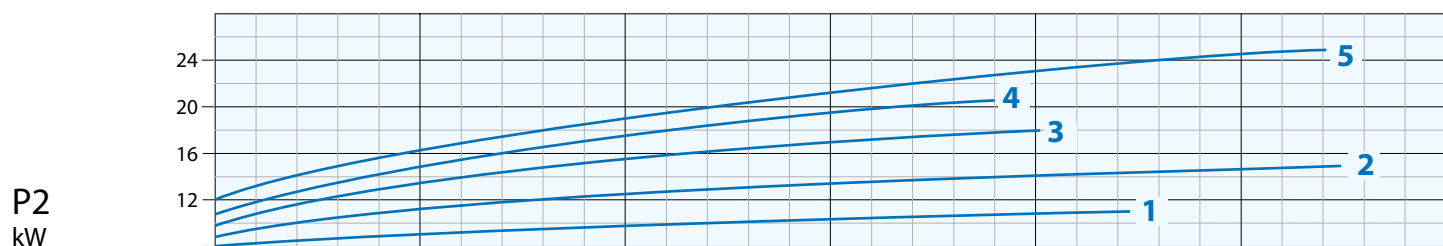
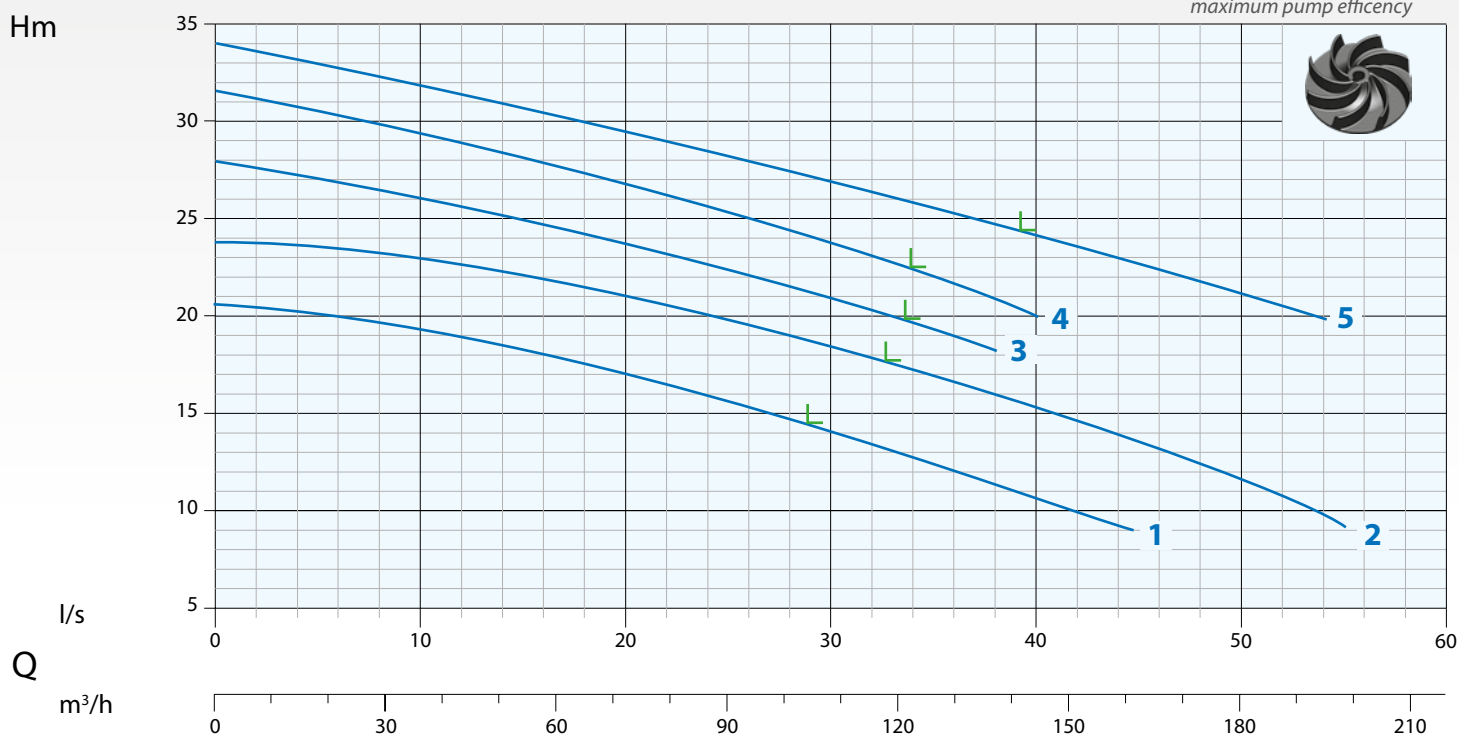

N°	Tipo Type	I/s l/m m³/h	6	10	14	20	24	30	34	40	50	54
			360	600	840	1200	1440	1800	2040	2400	3000	3240
1	VT 100/4/200 C.362	mt	20	19	18,5	17	16	14	13	10,5		
2	VT 100/4/200 C.363		23,5	23	22	21	20	18,5	17	15,5	11,5	10
3	VT 100/4/240 C.370		27	26	25	23,5	22,5	21	19,5	17,5		
4	VT 100/4/240 C.375		30	29	28,5	27	25,5	24	22,5	20		
5	VT 100/4/240 C.380		33	32	31	29,5	28,5	27	26	24	21	20

N°	Tipo Type	EX	Mandata Delivery	Passaggio Free Passage	kW			R.P.M. 1/min	A 3 Phase - 400V	Hz
					P1	P2	HP			
1	VT 100/4/200 C.362	•	DN100 PN16	90 mm	13,0	11,5	16	1450	23,8	50
2	VT 100/4/200 C.363	•			17,3	15	21		30,4	
3	VT 100/4/240 C.370	•			21	18	24,5		38,7	
4	VT 100/4/240 C.375	•			22,4	20	27		41	
5	VT 100/4/240 C.380	•			28,5	25	34		50,9	

• Pompa antideflagrante disponibile con certificazioni:
Available explosion proof pump with certifications:



EPT 17 ATEX 2703 X



Ex db IIB T4 Gb
Ex h IIB T4 Gb
0° ≤ Ta ≤ 40°

▽ Sommergenza minima
Minimum submersion

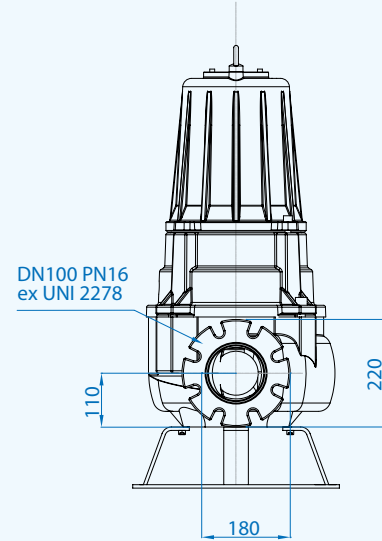
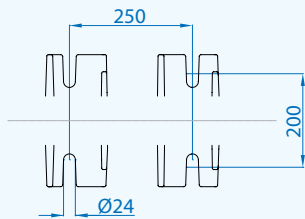
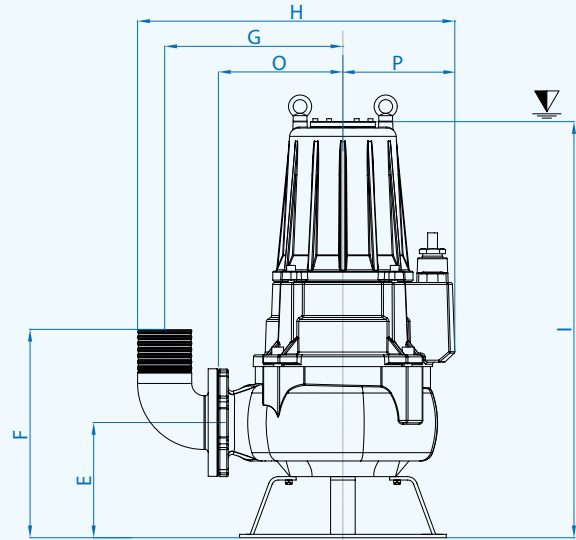
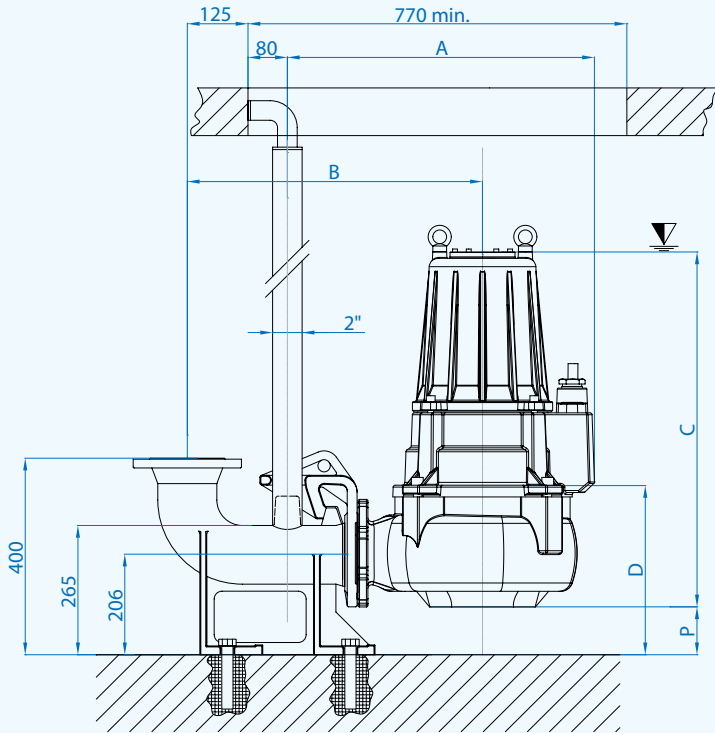

Quote in mm
Dimensions in mm

	A	B	C	D	E	F	G	H	I	L	M	N	O	P	Q
VT 100/4/200 C.362-363	618	605	730	335	238	426	362	645	855	932	902	183	255	92	227
VT 100/4/240 C.375-380	738	689	806	346	266	457	451	703	931	1050	270	237	342	60	249

Cavi / Cables

Pompe Pumps	Versione Version	Fasi Phases	Cavo Cable	Sezione cavo mm ² Cable cross section mm ²	mt
VT 100/4/200	Standard	3 ~ 400V	H07RN8F	10x2,5 Ø23*	10
	ATEX	Y-Δ	NSSHÖU-J	7x2,5+3x0,50 Ø20*	10
VT 100/4/240	Standard	3 ~ 400V	H07RN8F	7x4+3x1 Ø20,5*	10
	ATEX	Y-Δ	NSSHÖU-J	7x6+3x1 Ø24*	10

* Terminali liberi - Free terminals

Dimensioni imballo / Packaging dimension

Tipo - Type	X mm	Y mm	Z mm	Kg
VT 100/4/200 C.362	510	860	420	197
VT 100/4/200 C.363				210
VT 100/4/240 C.370				274
VT 100/4/240 C.375	570	950	670	275
VT 100/4/240 C.380				280

Accessori - Optional



Piede di accoppiamento
Tipo: DUTY 100 e B6
Automatic coupling foot
Type: DUTY 100 and B6

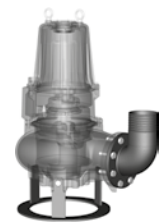

Curva flangiata con portagomma N3
Base di sostegno P7
Flanged hose connection N3
Foot support P7

Mandata Orizzontale DN150 PN16 - RPM 1450 1/min 4 poli

Horizontal Outlet DN150 PN16 - RPM 1450 1/min 4 poles

Immagine a solo scopo illustrativo
Picture for illustration purposes only



Curva di Prestazione Performance Curve

L = rendimento massimo pompa
maximum pump efficiency

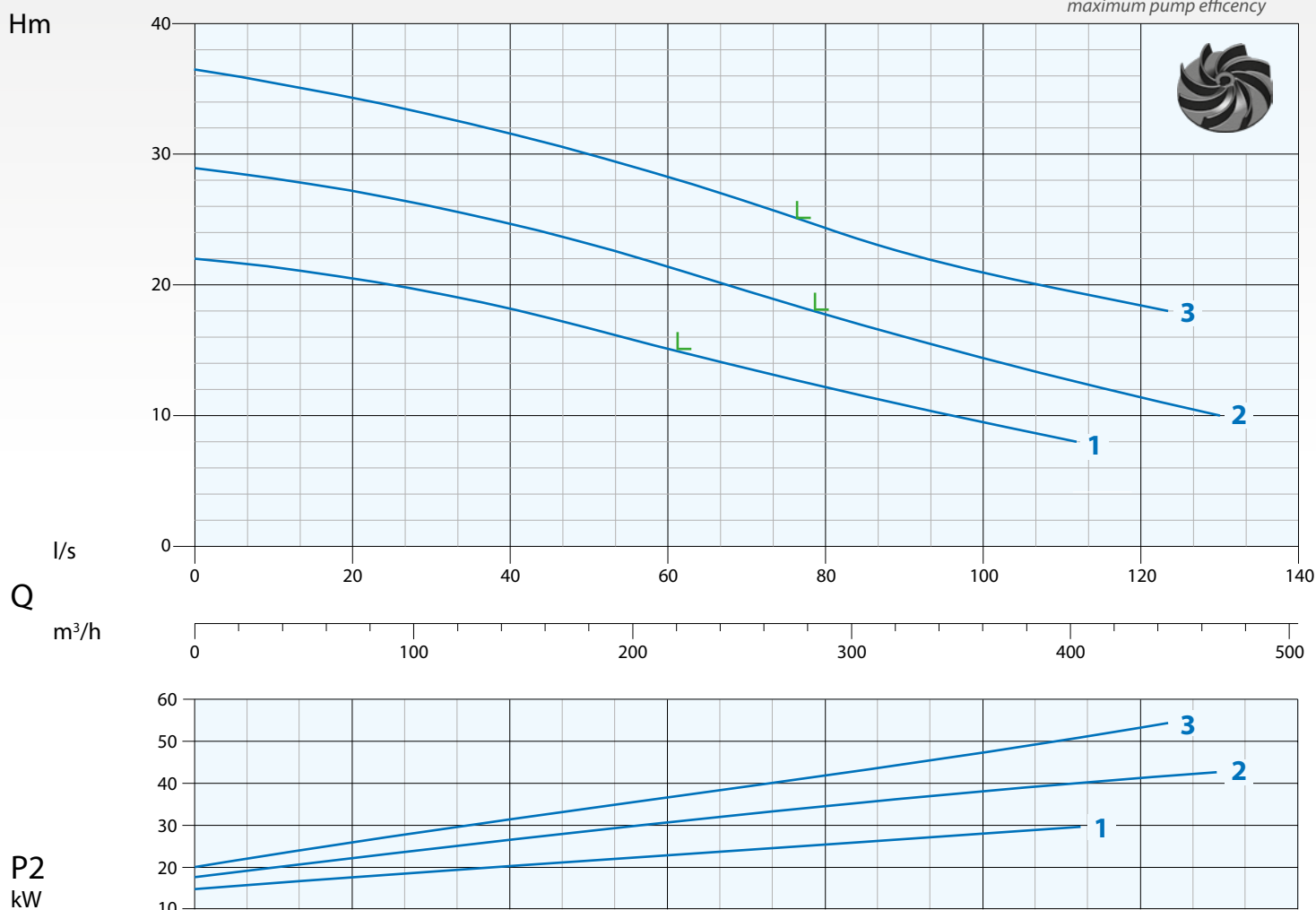

N°	Tipo Type	l/s l/m m³/h	10	20	30	40	50	60	80	100	110	120
			600	1200	1800	2400	3000	3600	4800	6000	6600	7200
1	VT 150/4/340 C.385	mt	21,5	20,5	19,5	18	16,5	15	12	9,5	8	
2	VT 150/4/340 C.390		28	27,5	26	25	23	21,5	18	14	13	11,5
5	VT 150/4/340 C.395		35	34	33	31,8	30	28	24	21	19,5	18,2

N°	Tipo Type	Mandata Delivery	Passaggio Free Passage	kW			R.P.M. 1/min	A		Hz
				P1	P2	HP		3 Phase - 400V		
1	VT 150/4/340 C.385			38	37	48		68		
2	VT 150/4/340 C.390	DN150 PN16	130 mm	49,4	45	61	1450	82,5		50
5	VT 150/4/340 C.395			58,9	54,5	75		100,1		

V4

∇ Sommergenza minima
Minimum submersion

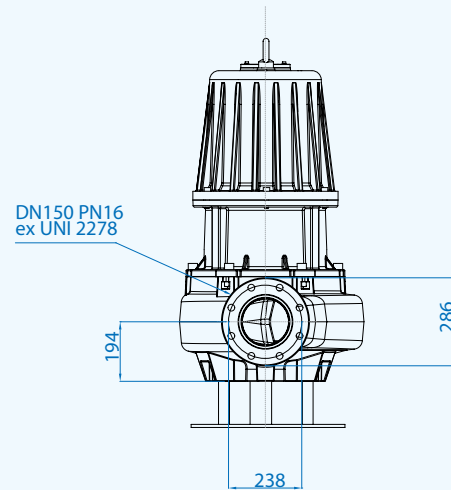
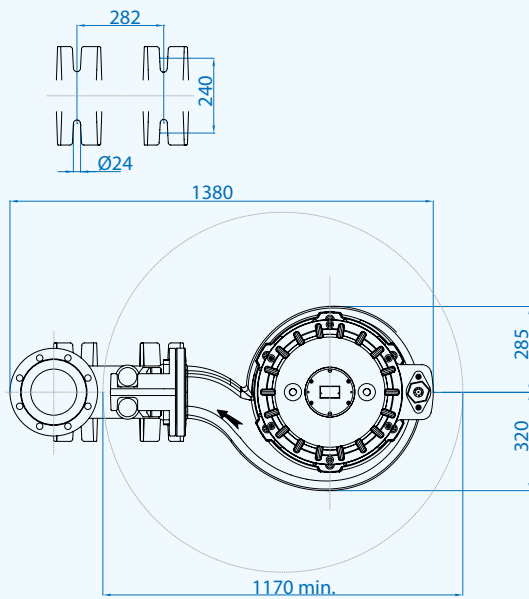
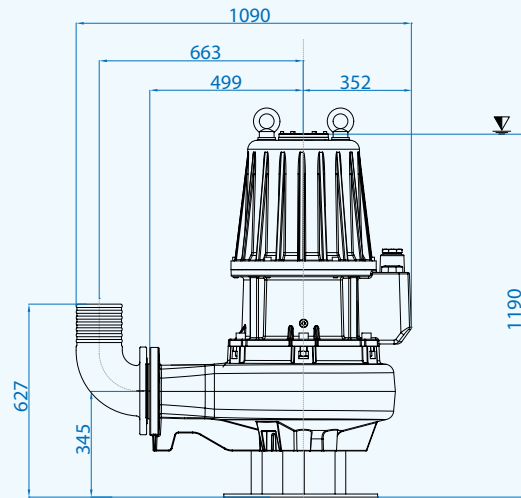
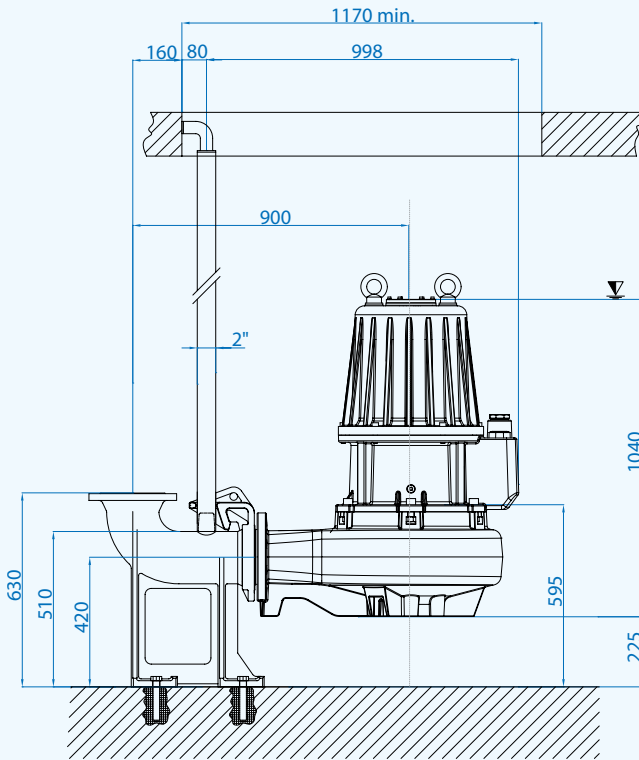

Quote in mm
Dimensions in mm

Cavi / Cables

Versione Version	Fasi Phases	Cavo Cable	Sezione cavo mm ² Cable cross section mm ²	mt
Standard	3 ~ 400V Y-Δ	H07RN8F	7x10+5x1 Ø29*	10

* Terminali liberi - Free terminals

Dimensioni imballo / Packaging dimension

Tipo - Type	X mm	Y mm	Z mm	Kg
VT 150/4/340 C.385				550
VT 150/4/340 C.390	980	1310	730	585
VT 150/4/340 C.395				590



Accessori - Optional



Piede di accoppiamento
Tipo: B8
Automatic coupling foot
Type: B8

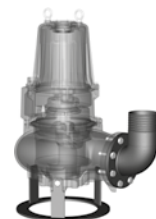

Curva flangiata con portagomma N4
Base di sostegno P8
Flanged hose connection N4
Foot support P8